

SYSTIMAX® Solutions

GigaSPEED® X10D Solution **What**

White Paper
June 2009

Contents

Achieving 10GBASE-T: A Mix of Bandwidth Efficient Coding, Digital Signal Processing and Revolutionary Cabling Performance	1
10 Gigabit Copper Technology	1
Understanding the relationship between Bits and Hertz	2
Spectral shaping	2
Multilevel Encoding	3
Line Codes for 10GBASE-T	3
Digital Signal Processing (DSP) Compensation Techniques	4
Parallel Transmission and Convolution Encoding	4
Adaptive Equalization: Compensation for channel insertion loss	4
Bi-directional Transmission and Echo Cancellation: Return Loss	5
Crosstalk Cancellation: Digital signal processing circuitry	6
Shannon Capacity	7
Revolutionary Cabling Performance	8
Conclusions	9

Achieving 10GBASE-T: A mix of Bandwidth Efficient Coding, Digital Signal Processing and Revolutionary Cabling Performance

In 5-10 years from now, cabling currently being installed can be expected to serve applications vastly more demanding than those we have today.

Enterprise networks have evolved rapidly to support the growing demand for bandwidth-hungry applications. End users are taking advantage of these applications to exchange more information in novel ways. Enterprise organizations generally find ways of consuming as much bandwidth as offered up to them very quickly. As the demand for bandwidth continues to increase, the next step in the evolution of networking has appeared - 10 Gigabit Ethernet. This paper explores the latest developments in 10 Gigabit Ethernet over copper cabling in some detail and introduces an optimized U/UTP cabling solution to serve the enterprise network market needs well into the future. This new U/UTP cabling solution with evolutionary design and revolutionary performance is the SYSTIMAX® GigaSPEED® X10D Solution.

10 Gigabit Copper Technology

With the ratification of the IEEE 802.3an 10GBASE-T standard, the development of a 10 Gigabit Ethernet specification for copper cabling is now complete. Due to the complexity of electronics to support 10GBASE-T, an early objective to support Category 5e was dropped, and the exact maximum distance over minimally compliant Category 6 cabling is still uncertain. Many expect that, as the clever chip designers further dive into this project, novel techniques will be developed which should increase the minimum guaranteed distance over generic Category 6 cabling. The margin over the minimum Category 6 specifications is also likely to extend the distance capability.

In simple terms, there are three ways of transmitting higher bit rates over cabling. One is to improve the cabling performance, the second is to improve the technology in the electronics, and the third requires a mixture of both. The latter is true for 10 Gigabit over copper. Transmitting 2.5 Gb/s on each of the four pairs is no easy task. It requires multi-level coding that transmits multiple bits per hertz, and channel bandwidth greater than that specified in existing Category 6 standards. Sophisticated Digital Signal Processing (DSP) techniques are also required to reduce the effects of within-channel impairments such as return loss and crosstalk (NEXT and FEXT). However, there is one parameter that cannot be compensated for in the electronics – Alien Crosstalk (the noise from adjacent cabling channels).

The IEEE 802.3an Task Force has actively explored these issues and interfaced with the ISO and TIA cabling standards to converge on its cabling channel requirements. The result of these developments led the IEEE 802.3an Task Force to adopt minimum cabling channel specifications for 10GBASE-T, and to recognize officially what became known as Model 1 Alien NEXT and Insertion Loss as the Model applicable to Category 6A or Class E_A. In addition, the Task Force agreed to set the maximum required channel frequency at 500 MHz.

Dramatic reduction of alien crosstalk and enhanced performance to a higher frequency are two key elements of the SYSTIMAX GigaSPEED X10D Solution. The following sections detail the background to the IEEE decisions, and the rationale behind the development of the GigaSPEED X10D Solution.

Understanding the Relationship Between Bits and Hertz

It is easy to get confused when assessing and specifying cabling system bandwidth and other performance requirements for current and future high-speed data applications. The confusion relates to the terms 'Megabits per second' (Mb/s) and 'MegaHertz' (MHz), or 'Gigabits per second' (Gb/s) and 'GigaHertz' (GHz). Mb/s and MHz are NOT the same thing although their numerical values may in some instances coincide. Cabling transmission properties such as insertion loss and crosstalk are typically specified as a function of Hertz (Hz), known as frequency. Digital data is transmitted as a series of '0's and '1's, called bits. The speed at which these digital symbols are transmitted is measured in bits per second.

The relationship between the frequency, or bandwidth, and the bit rate is governed primarily by the line codes used in the transmitter and receiver. Bandwidth-efficient line codes are used to provide higher bit rates in a given bandwidth or, alternatively, they can also be used to reduce the required bandwidth for a fixed bit rate. There are two main ways of improving the bandwidth-efficiency of the signal generated by the transmitter. One way is to change the characteristics of the shaping filter. A more powerful way of improving the bandwidth-efficiency is to replace the binary encoder with a so-called multilevel encoder. With such an approach, the bandwidth-efficiency can be improved dramatically depending upon the number of levels.

Spectral Shaping

With efficient spectral shaping, the square-shaped pulses that are used with LAN line codes are smoothed out in time to eliminate any sharp voltage transitions. As a result, fewer high-frequency components are generated by the pulses, which also decreases the bandwidth requirement for the channel.

An upper boundary of the improvement in bandwidth efficiency for truly band limited data signals, through improvement in the characteristics of the shaping filter, is a factor of two. This is known as Nyquist Theorem. According to the Nyquist Theorem, to ensure the accurate reproduction of an original analog signal, the sampling rate must be at least twice the highest frequency of the original signal. Applying this in the context of data rate and bandwidth, a signal of certain bit rate may still be recovered from a minimum bandwidth of half the bit rate.

Multilevel Encoding

With multilevel encoding, the pulses that are sent through the communication channel carry enough information to represent blocks of bits rather than one single bit, as is done with most of the first LAN line codes such as Ethernet. For a given bit rate, the use of multilevel-encoded pulses results in a decrease of the rate (often referred to as the Baud rate) at which the pulses have to be sent through the channel, which, in turn, decreases the bandwidth requirement for the transmission channel. Figure 1 below shows pulse streams for different multilevel line codes.

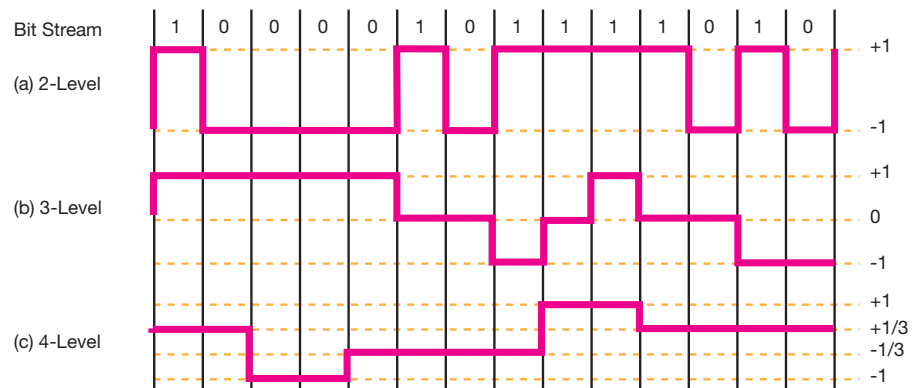

Nyquist Theorem, shown below, can be used as a quick guide to the minimum bandwidth required to transmit a certain bit rate, using a defined number of coding levels.

$$\text{Bit Rate} = 2 * \text{Bandwidth} * N \text{ bps, or alternatively, Bandwidth} = \text{Bit Rate} / (2 * N) \text{ Hz}$$

Where $N = \log_2(M)$ and M is the number of levels

Using this equation to achieve 10 Gb/s over a full 100 meters within the existing Category 6, 250 MHz bandwidth would require a 32 level coding scheme. This would be very difficult to develop and be very sensitive to noise. The IEEE has therefore focused on line codes that utilize bandwidth beyond 250 MHz.

Line Codes for 10GBASE-T

The IEEE has selected a PAM-16 line code, in a DSQ128 constellation (yielding 3.5 bits per symbol), with the addition of LDPC (Low Density Parity Check), an advanced technique to further improve the robustness of the line code. The specific LDPC technique is to send more information than required. With this technique, infrequent bit errors can be detected and automatically corrected allowing operation in noisier environments. The bandwidth requirement for this particular line code is less than 500 MHz.

Digital Signal Processing (DSP) Compensation Techniques

So far this discussion has shown how multilevel encoding can improve the bandwidth-efficiency of a system. However, is there a limit on the number of levels? Yes, the limit is set by the presence of noise. If levels are added, a point is reached where the receivers cannot distinguish between the individual signal levels because of the presence of noise. Noise therefore places a limit on the maximum rate at which we can transfer information. What really matters is the signal-to-noise ratio (SNR).

An important factor in the robustness of a line code is its performance in the presence of channel impairments (cabling) such as crosstalk, return loss, etc. By improving cabling performance, the channel impairments are reduced and therefore the system is less susceptible to noise and the SNR is improved. In addition, technology enhancements in the electronics can also improve the system's performance by canceling noise effects. So, as stated earlier in this document, the improvements in data transmission can be fuelled by both improved cabling and enhanced electronics. While the Nyquist equation gives a guide to the bandwidth requirements, there are other factors/compensation techniques that can affect the actual operation of the system and the subsequent channel requirements. The techniques commonly deployed with today's systems are:

- Parallel Transmission and convolution encoding
- Adaptive equalization (Attenuation)
- Bi-directional transmission and echo (Return loss) cancellation
- Crosstalk (NEXT and FEXT) cancellation

Parallel Transmission and Convolution Encoding

Probably what seems one of the most logical approaches to enabling high-speed transmission is the use of parallel transmission. Historically, data was transmitted on one single pair and received on another. With systems such as 1000BASE-T and 10GBASE-T, the data is split over all four pairs and therefore each pair is transmitting a quarter of the overall bit rate. This, by its nature, means that the required bandwidth for the whole system is now lower, although it adds complexity to the electronics.

The use of multiple pairs also enables another benefit. As has been stated previously, multilevel line codes increase the system's sensitivity to noise. But the reduced noise margin can potentially be recovered by the use of additional sophisticated coding, called convolution coding. For example, convolution coding proposed for 10GBASE-T allows error detection and correction by the receiver. By implementing the convolution coding across the four pairs, it improves the overall system's noise immunity. It again adds complexity to the electronics, but for the higher data rates, this is offset by the improvement in the overall system reliability and robustness.

Adaptive Equalization: Compensation for Channel Insertion Loss

As a signal travels down the length of the cable it gets reduced in amplitude. High frequency signals (the sharp edges of digital pulses) get attenuated more than low frequency signals and this effect results in distortion or jitter. All modern LAN electronics utilize some sort of equalization to compensate for attenuation distortion. How attenuation distortion compensation is implemented is design dependent (beyond the scope of many of the standards). One example of a compensating equalizer has four standard compensation settings namely 0-25m, 25-50m, 50-75m, 75-100m. These settings are "switched in" depending on what the electronics sense the attenuation of the cabling to be. This analog equalizer compensates for the majority of the attenuation distortion. The remaining portion is compensated by simple digital equalizers (one per receive pair).

Bi-directional Transmission and Echo Cancellation: Return Loss

When a signal is applied to cabling, ideally it is transmitted only to the far end of the cabling (i.e. travels in only one direction). In practice, part of the signal is reflected back towards the transmitter due to discontinuities within the cabling (mainly cord-to-cable impedance mismatches and connectors). The amount of signal reflected back is characterized by return loss. The greater the return loss (measured in dB), the less the signal is reflected. Return loss degrades with frequency, becoming more significant at higher frequencies. To ensure error free transmission, the reflected signal must be small compared to the desired receive signal at all relevant frequencies. The amount of undesired reflected signal can quickly exceed the desired receive signal as frequency increases, and is unacceptable for error free transmission. The effects of the undesired reflected signal can be reduced using sophisticated digital return loss cancellation or "echo cancellation" techniques. The use of bi-directional transmission for systems such as 10GBASE-T, where the transmit and receive signals share the same pair using a device called a hybrid, increases the importance of echo cancellation for reliable transmission.

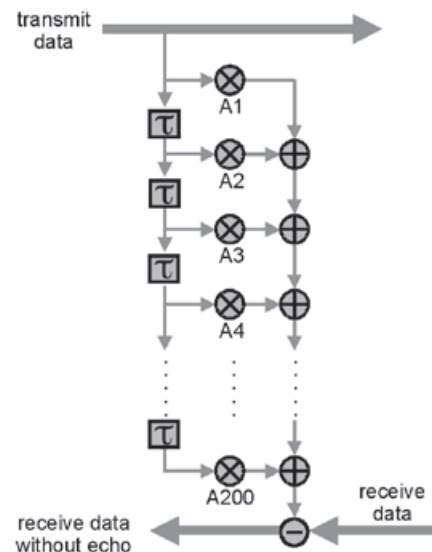

Sophisticated echo cancellers can learn and adapt to echo/return signal. Every time a bit is transmitted, the electronics can predict the amplitude and echo response as a function of time. The digital "taps" of a delay line filter are adjusted accordingly. The predicted echo response is subtracted from the total incoming receive signal to "cancel" the effect of the echo. It should be noted that the echo is not correlated to the desired signal coming from the other end of the cabling. By slowly adjusting the taps using sophisticated algorithms, the echo canceller will track only the echo, thus avoiding cancellation of the desired receive signal.

Crosstalk Cancellation: Digital Signal Processing Circuitry

A similar situation to echo occurs at each receiver due to near-end crosstalk noise. Where the magnitude of the Power Sum Near-End Crosstalk (PSNEXT) noise is more than the electronics can accommodate for error free transmission, cancellation of near-end crosstalk is employed. The same echo cancellation technique described above can be used to cancel this noise. The correlation between the transmit signal applied to one pair and the receive signal on another pair can be determined in terms of magnitude and time delay. The induced crosstalk noise can thus be cancelled using sophisticated techniques. Each receive pair is corrupted with near-end crosstalk noise from three other pairs, each of which needs its own crosstalk canceller. Therefore, a total of twelve NEXT cancellers are needed at each end of the channel.

Two other forms of noise that must be considered are Power Sum Far-End Crosstalk (PSFEXT) and Alien Crosstalk. Techniques were developed for PSFEXT cancellation for 10GBASE-T. As with NEXT cancellation, a total of twelve FEXT cancellers are needed at each end of the channel. That leaves Alien Crosstalk as the main limiting noise factor. All the above play a part in defining the potential bit rate, the actual bandwidth and SNR requirements of the system. It is a complex mesh of potential solutions and techniques.

Shannon Capacity

As a way of illustrating the relationship between bit rate, bandwidth and SNR, there is a theoretical maximum to the rate at which information passes error free over the channel. This maximum is called the channel capacity, C , and can act as a guide, just as the aforementioned Nyquist equation.

The famous Shannon Law states that the channel capacity C is given by:

$$C = B \cdot \log_2(1 + (S/N)) \text{ bits/second}$$

Note that Signal to Noise ratio, S/N , is linear in this expression.

The theorem makes no statement as to how the channel capacity is achieved. In fact, channels only approach this limit. A Shannon capacity much higher than the required actual LAN bit rate is required to give assurance of reliable transmission.

In relation to the 10GBASE-T developments, it means that the bandwidth, bit rate, signal strength, noise, channel impairments (cabling performance) and the bit error rate of the system are all interlinked. Improvements in one or more area affect and/or rely upon improvements in others. Specifically for cabling, improvement in channel performance results in a positive outcome for the overall system.

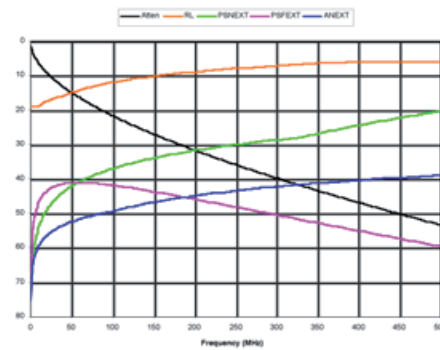

Figure 2(a): Category 6 cabling to 500 MHz

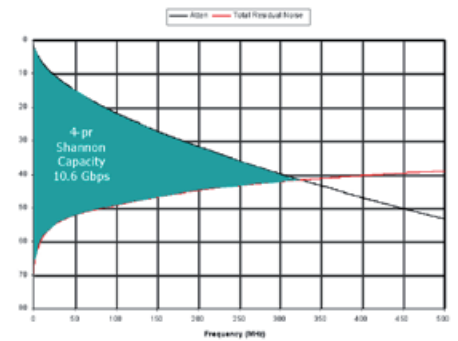

Figure 2(b): Composite Category 6 + DSP

To illustrate this, Figure 2(a) shows the channel performance for a Standards based Category 6 cabling system with performance extrapolated to 500MHz, detailing all the relevant electrical performance parameters. Assuming DSP compensation techniques discussed earlier are employed for 10GBASE-T, Figure 2(b) shows the composite performance, highlighting that Insertion Loss and Total Residual Noise (dominated by Alien Crosstalk but including internal channel parameters as well) become the limiting parameters in the channel. Applying Shannon's Law to this channel concludes that the Category 6 channel has a maximum capacity of 10.6 Gb/s for 100 meters. This is not enough to support a reliable 10 Gb/s.

To achieve the full 100-meter distance with a capacity large enough to support a reliable 10 Gb/s, requires improvements in insertion loss and Alien Crosstalk performance. This is why the IEEE 802.3an Insertion Loss and Alien NEXT is the chosen model for new cabling.

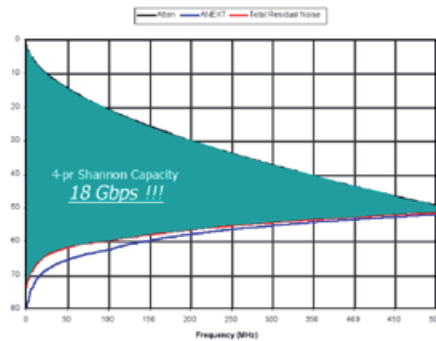

Figure 3 shows the composite performance of the IEEE 802.3an Task Force's channel specification and the DSP compensation techniques. The result is a Shannon capacity of approximately 18 Gb/s for a 100-meter channel, giving a cabling channel with enough capacity to support 10 Gb/s.

Figure 3: Composite IEEE Model 1 + DSP

To meet these improved cabling channel requirements, each cabling component must combine high performance with close matching to other system components. Achieving this was a focus of development at CommScope Labs.

Revolutionary Cabling Performance

The breakthrough result of the CommScope Labs 10 Gb/s development work is the SYSTIMAX GigaSPEED X10D Solution. It is a natural evolution to Class E/Category 6 cabling.

The key performance parameters of the GigaSPEED X10D Solution are Channel Return Loss, Insertion loss and Crosstalk, all of which have been balanced to achieve this cabling solution's revolutionary performance.

Channel **Return Loss** (RL) is a measure of the consistency of impedance through all the channel's components, which is important in avoiding signal reflections that can cause losses and data errors. The GigaSPEED X10D Solution exhibits excellent return loss performance to 500 MHz made possible by tuned channel components.

Insertion Loss, a key parameter affecting 10 Gb/s performance, is the reduction in a signal occurring within a channel or link. It is signal frequency and distance dependent, and determines the maximum length of a channel before the receiver fails to pick up the signal. The GigaSPEED X10D Solution exhibits far superior insertion loss to 500 MHz in excess of the current Category 6/Class E and Class F standards and, more importantly, the IEEE requirements.

Of all the factors affecting high-speed cabling performance, Crosstalk is probably the most important. The crosstalk that primarily limits performance in the proposed solutions for 10GBASE-T is Alien Near End Crosstalk (ANEXT). In addition, augmented performance of existing parameters such as Near End Crosstalk (NEXT), Far End Crosstalk (FEXT) and Attenuation-to-Crosstalk Ratio Far-End (ACRF) is also required to 500 MHz. The GigaSPEED X10D Solution exhibits revolutionary Alien Crosstalk suppression in excess of IEEE 802.3an 10GBASE-T requirements, while continuing the CommScope heritage of superior NEXT and FEXT margin.

Conclusion

10 Gb/s LAN transmission capability is primarily a function of insertion loss, crosstalk, coding scheme, SNR, DSP techniques and required bit error rate (BER). Therefore for a set BER, encoding and DSP techniques, the improvement in insertion loss and reduction in all types of crosstalk exhibited by the GigaSPEED X10D Solution is key to support for 10GBASE-T over U/UTP.

10 Gigabit Ethernet will become the technology of choice for enterprise, metropolitan and wide-area networks. In terms of physical media, 10 Gigabit Ethernet supports distances to 300 meters on multimode fiber (550 meters on SYSTIMAX LazrSPEED® 550 cabling), and over 40 km (or more) on singlemode fiber (SYSTIMAX TeraSPEED™ cabling). The development of 10GBASE-T and support over U/UTP cabling, initially in data centers but ultimately to the desktop, will bring a whole new world of opportunity for support of bandwidth intensive applications. With the introduction of the SYSTIMAX GigaSPEED X10D Solution, 10 Gigabit Ethernet over U/UTP can become a part of infrastructure deployments today.



www.commscope.com

Visit our Web site or contact your local CommScope representative for more information.

© 2011 CommScope, Inc. All rights reserved.

All trademarks identified by ® or ™ are registered trademarks or trademarks, respectively, of CommScope, Inc.

This document is for planning purposes only and is not intended to modify or supplement any specifications or warranties relating to CommScope products or services.

WPB-62 06/11