

CATALOG NO.	DESCRIPTION	WEIGHT (lbs.)
UNA-FX-VGA9-XX	9-PIN VGA COUPLER	0.1

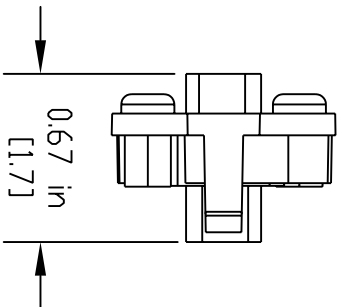
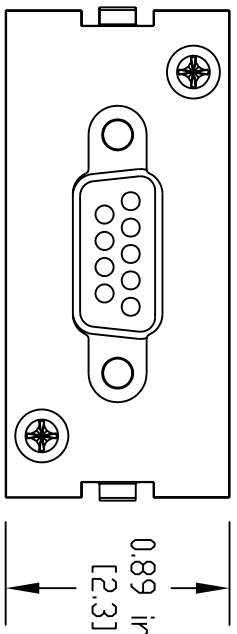
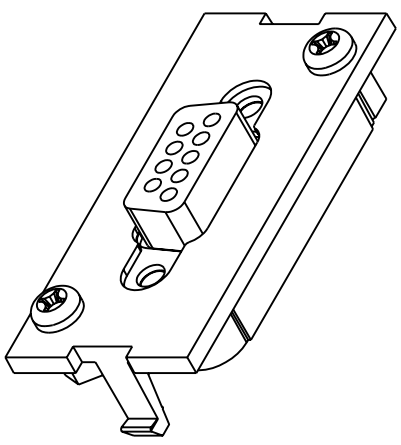
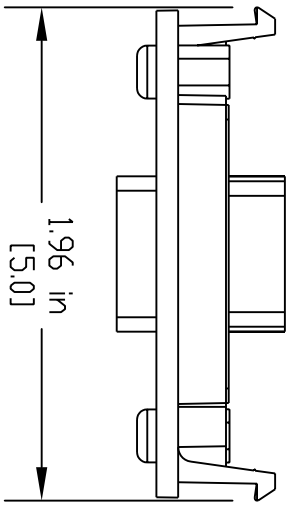

NOTES:

1. SEE UNIPRISE CATALOG FOR PART NUMBER SUFFIXES TO INDICATE COLOR/PKG.
2. SEE UNIPRISE CATALOG FOR COMPLETE LIST OF PARTS RELATED TO THE USE OF THIS PRODUCT.

3. DIMENSIONS IN PARENTHESES ARE IN METRIC.

4. XX =BK-BLACK
=WH-WHITE
=IV-IVORY
=GY-GRAY

UNA-FX-VGA9-XX

COMMSCOPE, INC HICKORY, NORTH CAROLINA



DRAWN BY		DATE	DWG NO.
DATE			

REV	DATE	ECR	DESCRIPTION	BY