

General

This instruction sheet provides procedures for the mounting of and wire routing used in the 730 Jack.

Note: 730 Jack Building Entrance Protector Units are for indoor use only and can be stacked up to six units high. The bottom of the first unit in a column should be at least 21 inches (533.4 mm) from the floor. When installing the units in a stacked formation, ensure that the top of the highest unit is not so high as to require a ladder for installation or for maintenance.

How to Contact Us

- To find out more about **Carrier Apparatus** products, visit us on the web at: <http://cw.commscope.com/>
- For technical assistance regarding Carrier Apparatus products: contact your local CommScope account representative or Commscope technical support at 1-800-344-0223.
- Report any missing or damaged parts to CommScope customer service in Omaha, Nebraska, at 1-866-539-2795.

Tools Required:

- Screwdriver, Phillips head
- Screwdriver, Flat Blade
- Drill
- KS- or 216-type tool

Override Protection

To open the top of a 730 Jack that has been padlocked, use a KS-type tool or a 216-type tool to loosen the top screw of the override mechanism. Refer to Figure 1. Rotate the override mechanism to the side to expose the outside cover screw. Use a screwdriver to loosen the outside cover screw and open the outside cover.

Opening the 730 Jack

Use a screwdriver to open the outside cover of the 730 Jack.

Use a 216-type or KS-type tool to open the bottom layer of the 730 Jack.

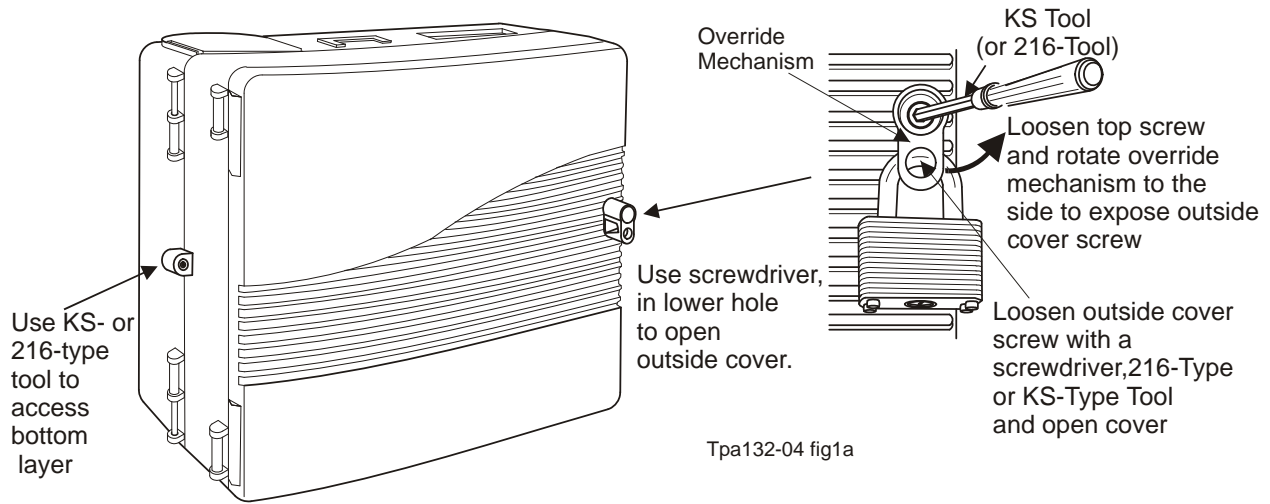

Figure 1. Opening 730 Jack

Mounting Procedure

1. Attach three wire guides (provided with unit) to right side of each jack to be mounted. Refer to Figure 2.

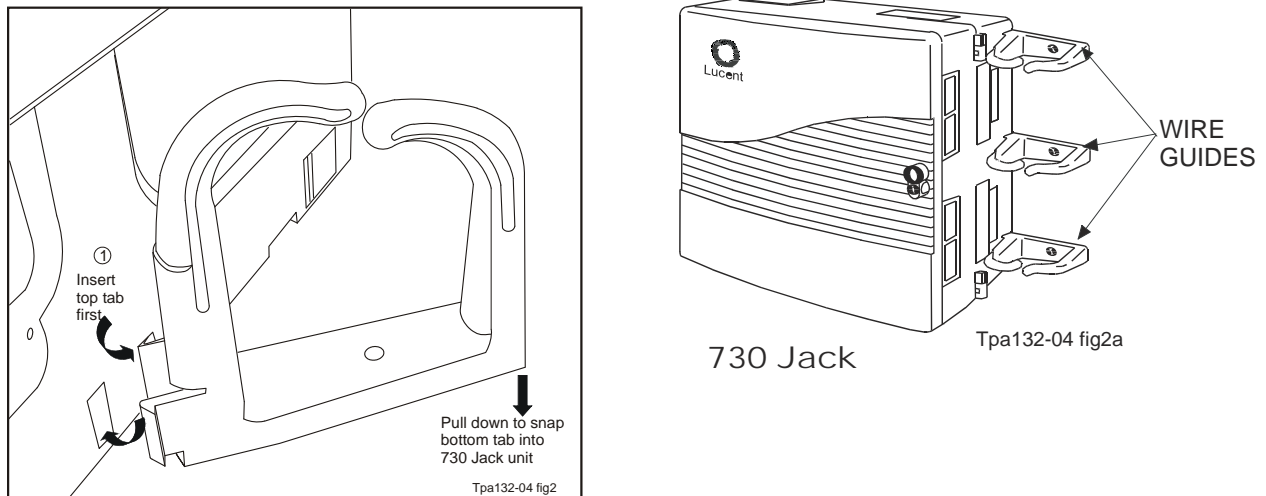

Figure 2. Wire Guides

2. Locate and drill the required 1/8-inch (3.2 mm) diameter pilot holes as shown in Figure 3. Mounting template (provided with unit) may also be used to locate the pilot holes.

3. Install short wood screws (provided with units) into pilot holes leaving 5/8-inch (16 mm) to 3/4-inch (19 mm) clearance between each screw head and mounting surface.
4. Install first protector on lowest set of screws as follows:
 - a. Open bottom layer to expose mounting keyholes in the splice chamber.
 - b. Position protector so keyholes are over the two screws. Push forward and down to engage.
 - c. Tighten the two screws, accessible from inside the splice chamber, to secure protector.
 - d. Insert two long wood screws (provided with unit) through mounting holes located in right-hand side of base and tighten to secure protector to wall.

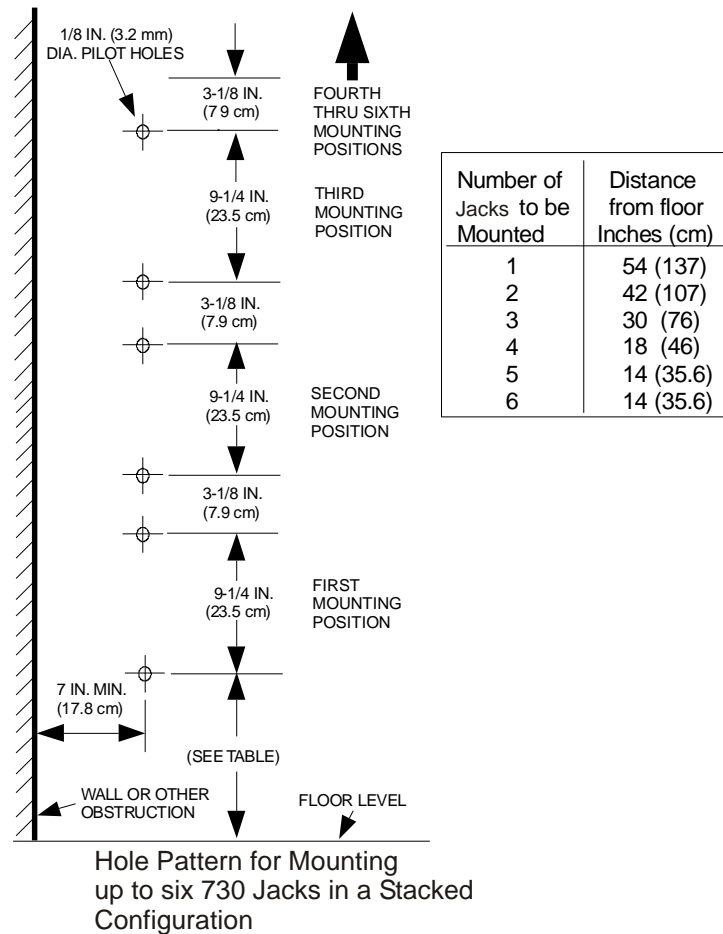
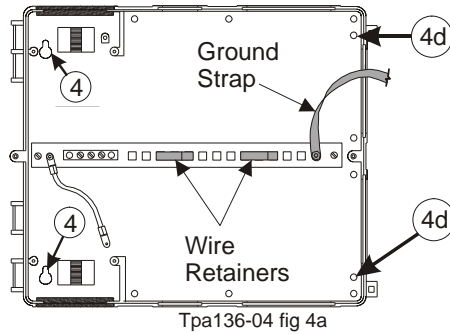

Figure 3. Hole Pattern for Mounting up to six 730 Jack Units in a stacked configuration

5. Install each of the remaining 730 Jack Units on top of previously mounted 730 Jack following Steps 1 through 4.

Material ID 848 031 928
Instruction Sheet

6. Note that cable entry may be from the top, bottom, or may be gel filled.
 - a. For **top fed** outside plant cable entry, open splice chamber of installed unit and remove all rubber grommets except bottom grommet of lowest unit.
 - b. For **bottom fed** outside plant cable entry, open splice chambers of installed unit and remove all grommets except top grommet of the top unit.
 - c. For **gel filled** cables, use only bottom entry.



730 Jack (Opened)

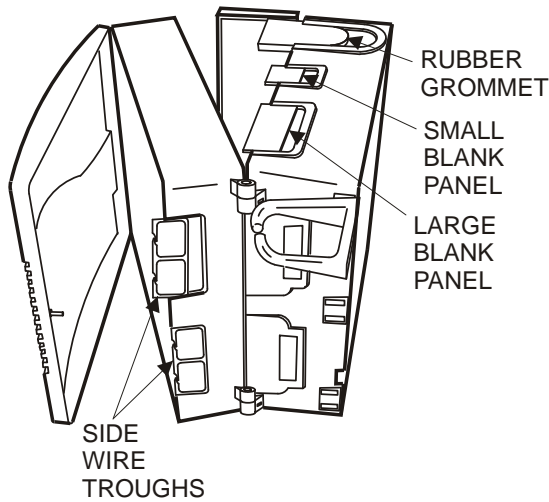

SLIDING WIRE TROUGH

IF NEW TROUGH IS NEEDED, INSTALL NEW WIRE TROUGH SUCH THAT TOP EDGES MATCH

TOP EDGE OF BEP

TOP EDGE OF WIRE TROUGH

INSERT WIRES THROUGH SLOT

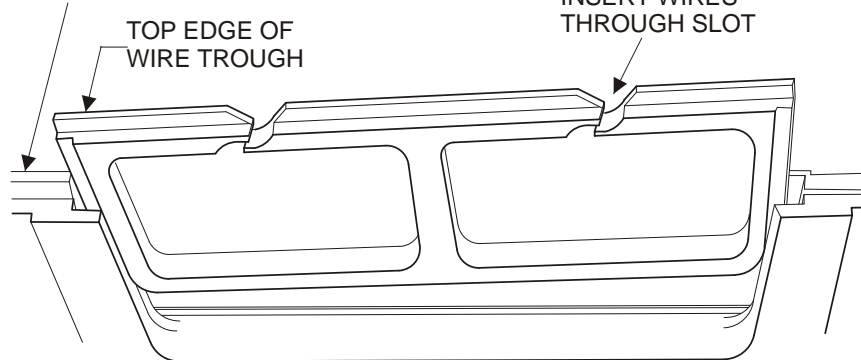

Figure 4. 730 Jack Unit

Wiring Procedure

1. Using short pieces of No. 6 gauge (4 mm) solid conductor wire, bridge ground connections between adjacent 730 Jack Units.
2. Connect a No. 6 gauge (4 mm) solid conductor ground wire from an approved building ground to the protector ground per local practices.
3. Use one of the previously removed grommets and cut around the grooved circular pattern, which is equal or slightly smaller than the diameter of cable entering the 730 Jack. Make additional 0.1-inch (2.5 mm) long radial cuts around the precut hole at all marked radial lines.
4. Insert cable into grommet and pull through required length "A" as indicated in table.
5. Secure incoming cable to wall about 10 inches (25.4 cm) before entry gate.

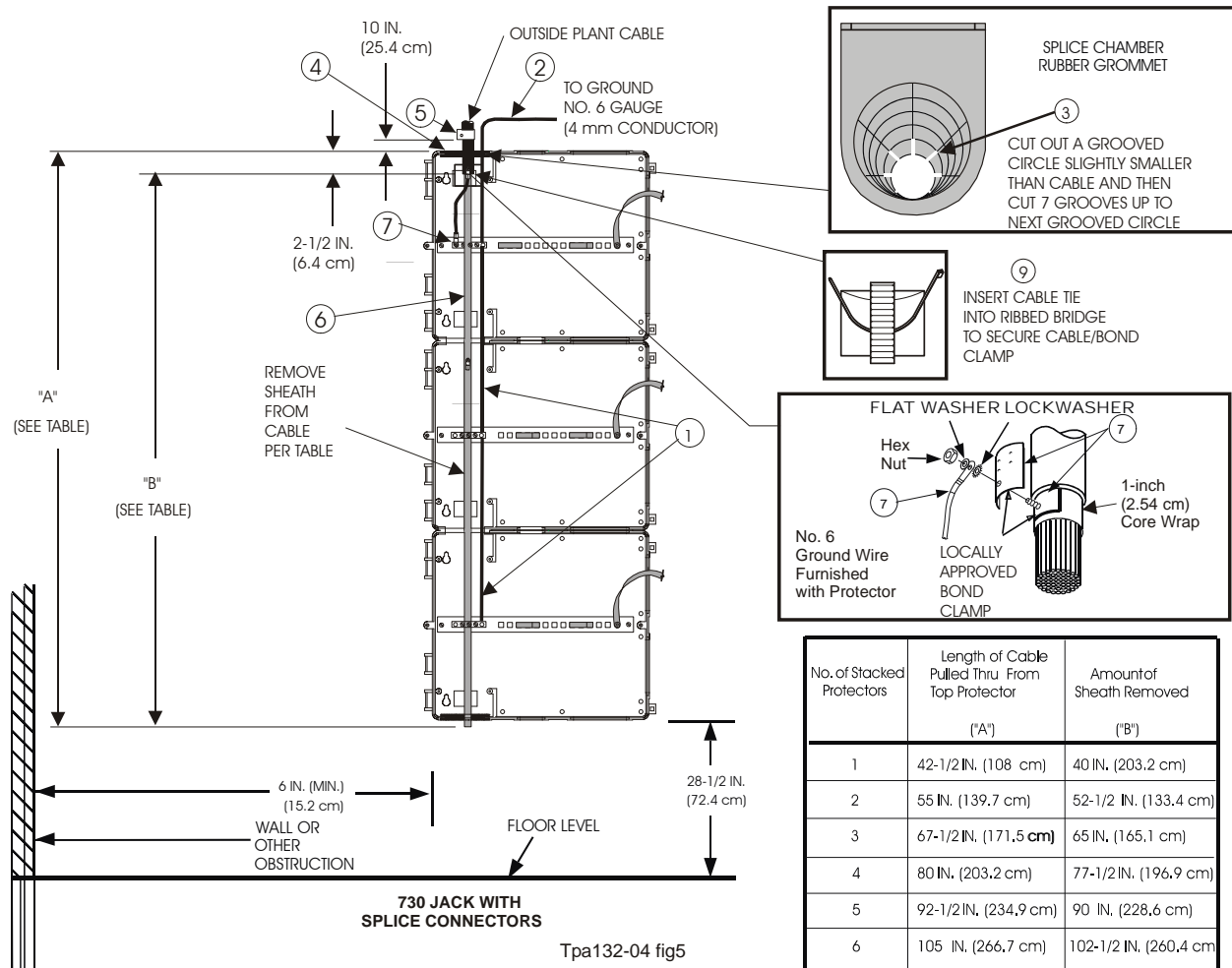

Figure 5. 730 Jack Unit Wiring Layout

Material ID 848 031 928
Instruction Sheet

6. Strip sheath from cable 2-1/2 inches (6.35 cm) past entry gate. Conductor length is shown in table as distance "B".
7. Install bond clamp (customer-supplied) on incoming cable per local practices and connect to ground block. Make sure there is electrical continuity between ground strap and bond clamp.

Notes:

- a. **Only the ground strap closest to cable entry point will be used to ground incoming cable. Ground straps on all other protectors will not be used.**
 - b. **When terminating gel-filled cable, remove all filling compound from exposed conductors, and apply two wraps of vinyl tape tightly around first 3 inches (7.6 cm) of loose conductors extending beyond cable jacket.**
8. Push rubber grommet (on cable) to bottom of guides located at entry gate.
 9. Using the cable ties (furnished), secure cable/bond clamp to the ribbed bridge located at entry gate (rear surface of splice chamber).
 10. Terminate cable conductors in splice connectors per local practices.
 11. Dress splice connectors and conductors neatly into splice chambers. Group connectors to form a bundle against back of splice chamber and secure with attached Velcro strap. **Exercise care to prevent bends or kinks in the conductors.**
 12. Close splice cover and lower layer.

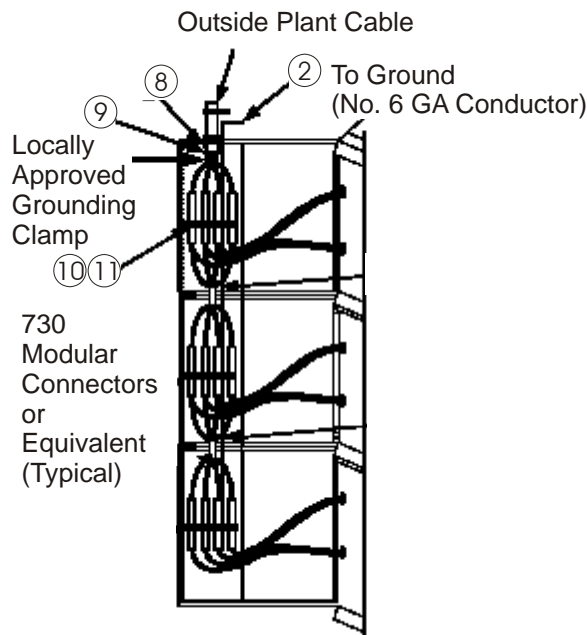

Tpa132-04 fig6

Figure 6. Customer Bridge

Instructions for Circuit Wiring

1. Route customer wires to customer bridges through wiring troughs located on right hand side of the unit and front right hand edge of RJ11 chassis.
2. Unplug assigned RJ11 plug.
3. Loosen two screws on assigned customer bridge.
4. Strip about ½ inch (12.7mm) from ends of customer wires.
5. Wrap stripped green wire clockwise around TIP screw between two washers, and then wrap stripped red wire clockwise around RING screw between two washers.
6. Tighten screws making sure the stripped parts of wires are not touching each other.
7. Plug RJ11 plug into jack.

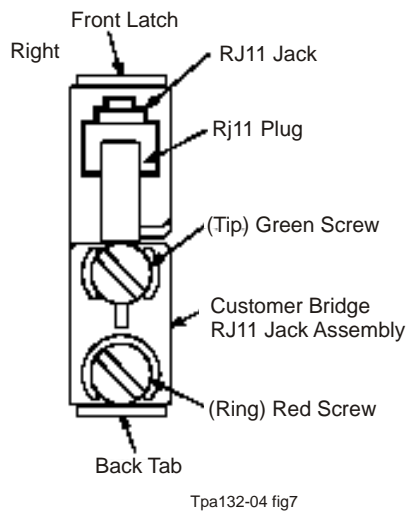

Figure 7. Top View of Customer Bridge/RJ11

Replacement of Customer Bridge/RJ11 Jack Assembly and Customer Bridge

1. Locate customer bridge/RJ11 jack assembly to be replaced.
2. Remove existing customer wires from the customer bridge screws.
3. Remove customer bridge/RJ11 jack assembly by pressing inward and out on its front latch using a flat blade screwdriver.
4. Pull outward on disconnected customer bridge/RJ11 jack assembly until at least 4 inches (10.2cm) of its red and green wires are exposed and accessible.
5. Hold red and green wires in place to prevent them from slipping back into R11 chassis once they are cut from old customer bridge/RJ11 assembly.
6. Cut red and green wires adjacent to old customer bridge/RJ11 jack assembly.
7. Use 700-type splicing connector, or equivalent, to splice red and green wires to replacement RJ11 jack assembly.
8. Install replacement assembly by inserting back tab into slot and pressing down on front latch.
9. Insert RJ11 plug into replacement RJ11 jack assembly.
10. Install customer wires onto the new customer bridge screws as described in Instructions for Circuit Wiring.

Installation of Security Cap on Customer Bridge

1. Loop a cable tie around the bottom post of Customer Bridge and slide through the groove between the two posts.
2. Press Security Cap down over the two screws of the customer bridge.
3. Wrap the cable tie around the Security Cap and join the cable tie ends.
4. Tighten the cable tie around Security Cap to prevent access to the customer bridge.
5. Trim the cable tie to remove the excess length.

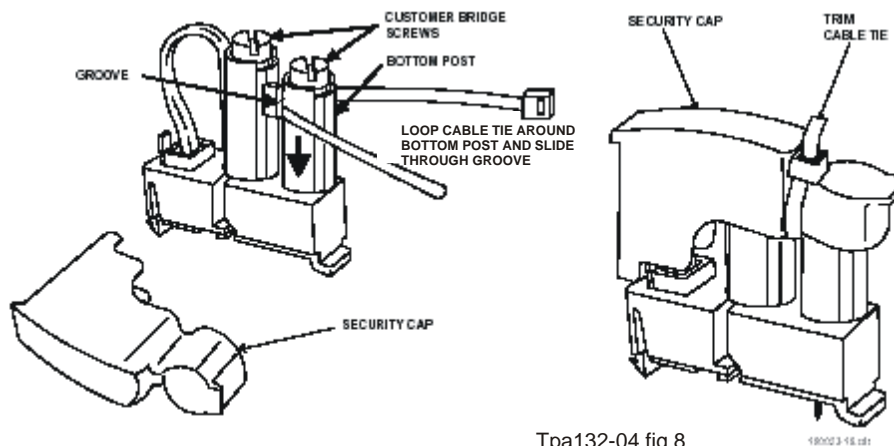

Figure 8. Detailed View of Customer Bridge